

Job Name:

System Reference:

Date:

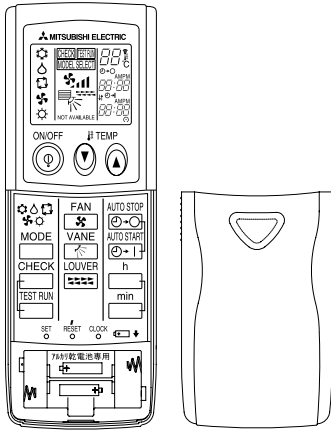

PAR-FL32MA-E

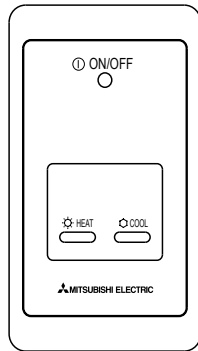

PAR-FA32MA-W
(Signal receiving unit)

PAR-FL32MA-E WIRELESS MA REMOTE CONTROLLER SPECIFICATIONS

- Used in conjunction with PAR-FA32MA MA Remote Controller Receiver.
- Maximum signal receiving distance is approximately 22' (7m).
- Maximum signal receiving angle is approximately 45° to the left and right of center.
- Install a minimum of 3' (1m) away from a television or radio.
- Controls group operation for up to 16 indoor units in am single group.
- Supports both Fahrenheit and Celsius.
- User Functions allows user to set:
 - On/Off
 - Set Temperature
 - Operation Mode (Heat, Cool, Dry, Fan, Auto [R2-Series only])
 - Fan Speed setting
 - Airflow direction (depending on indoor unit)
- Range of set temperature depends on the indoor unit:
 - Cool/Dry: 67°F to 87°F / 19°C to 30°C
 - Heat: 63°F to 83°F / 17°C to 28°C
 - Auto: 67°F to 83°F / 19°C to 28°C
- On/Off timer: One On/Off setting for one day.
- Function Lockout: Individually prohibits all functions of each remote controller.
- Grouping: Can only be used in same group with PAC-YT53CRAU-J Simple MA Remote Controllers, PAR-33MAA-J Deluxe MA Remote Controllers, and other wireless receivers with up to two remote controllers per group. Wireless remote controller cannot group indoor units served by separate outdoor units.
- Dimensions: 2-1/4" W x 6-1/4" H x 3/4" D (58 x 159 x 19mm).

OVERVIEW OF CITY MULTI® CONTROLS NETWORK (CMCN)

- Consists of TG-2000 integrated system software, AG-150/GB-50ADA/GB-24/TC-24 centralized controllers, web browsers, timers, remote controllers, and BMS interfaces.
- TG-2000 integrated system software supports up to 40 AG-150/GB-50ADA centralized controllers (licensed for PC software features) for a maximum of 2,000 indoor units from a single PC.
- AG-150 centralized controller operates up to 50 indoor units with optional control via a field-supplied PC with licensed software.
- GB-50ADA centralized controller operates up to 50 indoor units via a field-supplied PC with licensed software.
- GB-24 central controller operates up to 24 indoor units via a field-supplied PC with licensed software.
- TC-24 standalone centralized controller operates up to 24 indoor units via an integral touch screen interface.
- Remote controllers consist of Deluxe MA, Simple MA Wireless MA, and ME.
- I/O controllers consist of DIDO (PAC-YG66DCA) and AI (PAC-YG63MCA) for third-party equipment control.
- LonWorks® and BACnet® interfaces also available.
- Interlocking of LOSSNAY® ERV units for control via the AG-150/GB-50ADA/GB-24/TC-24 centralized controllers.

PAR-FA32MA-W WIRELESS MA REMOTE CONTROLLER RECEIVER SPECIFICATIONS

- On/Off lamp to indicate unit operation and error status.
- Enable heat and cool operation (at pre-set parameters) from the receiver for when the remote is not operational.
- Wiring: Connects using two-wire, stranded, non-polar control wire to TB-15 connection terminal on the indoor unit. Requires crossover wiring for grouping across indoor units.
- Dimensions: 2-3/4" W x 4-3/4" H x 7/8" D (70 x 120 x 23mm).

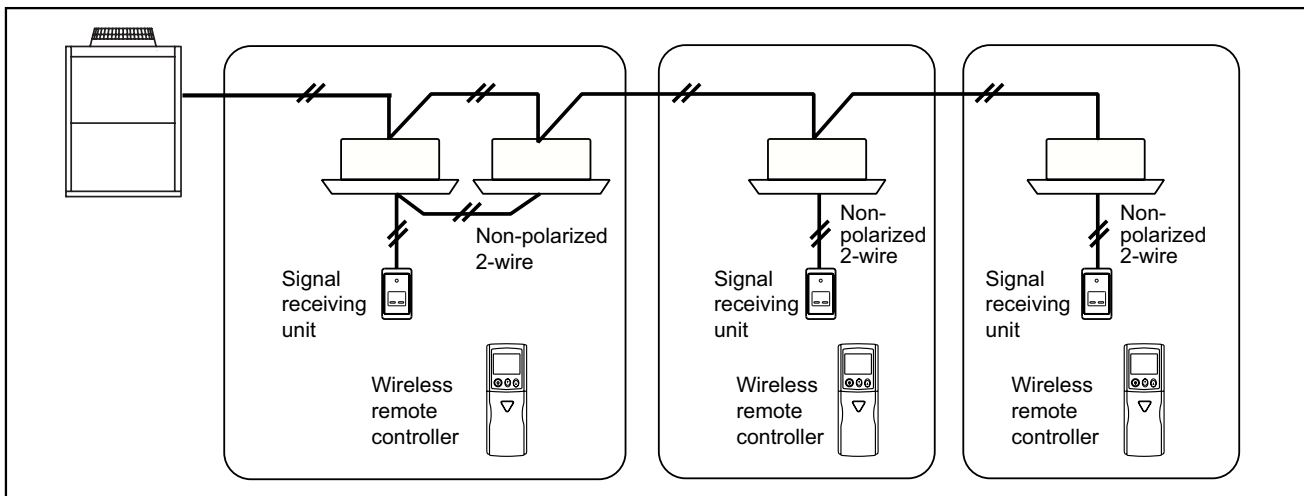

DIMENSIONS: PAR-FL32MA-E AND PAR-FA32MA-W

PAR-FL32MA-E

Unit:mm[in.]

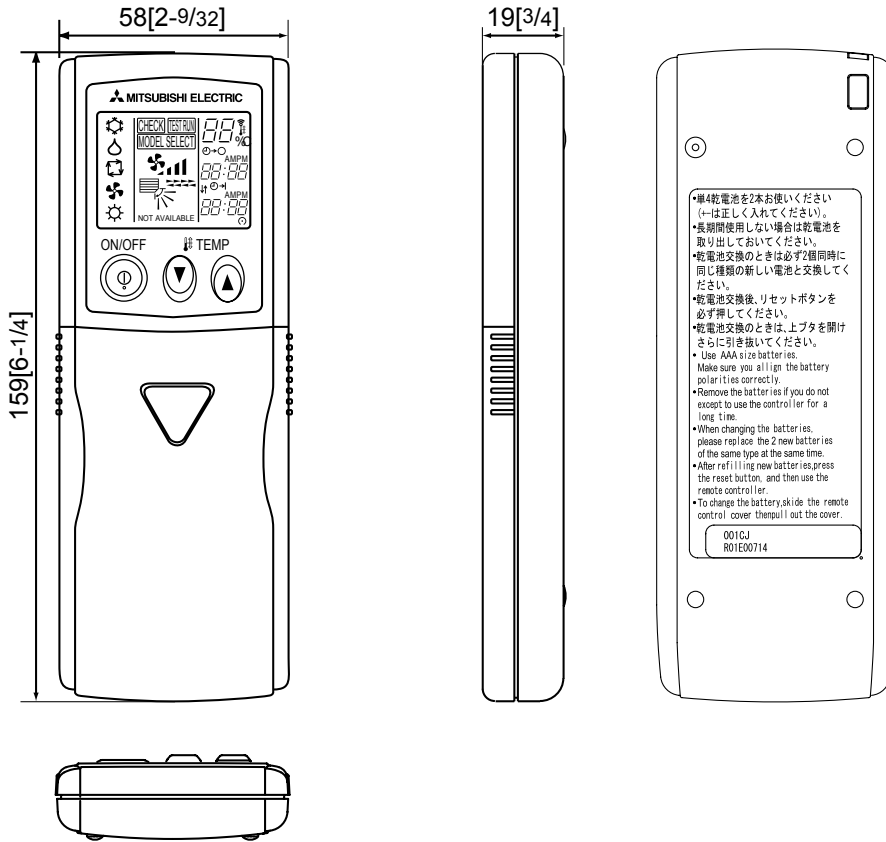

PAR-FA32MA-W

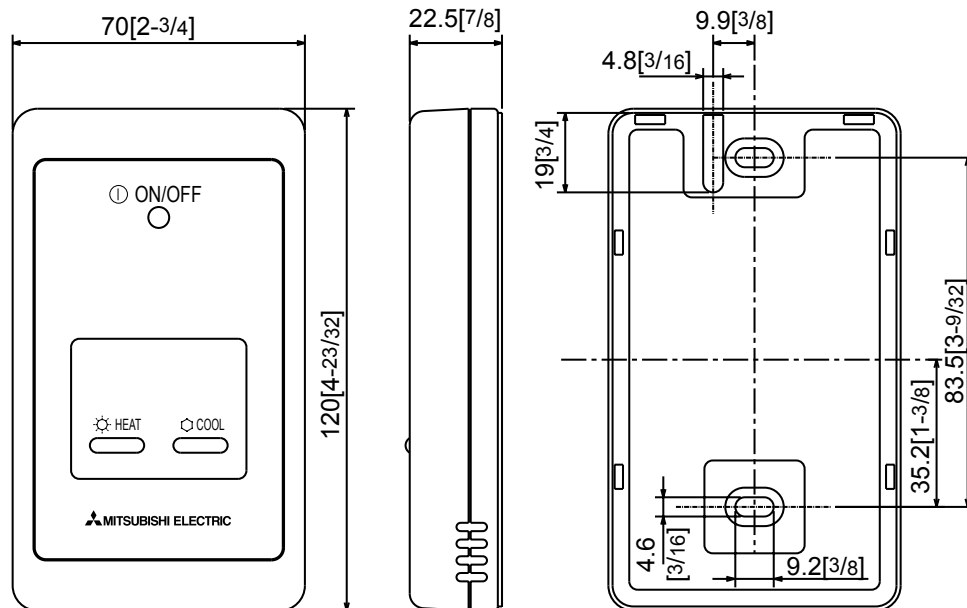

COOLING & HEATING

1340 Satellite Boulevard, Suwanee, GA 30024
Toll Free: 800-433-4822 www.mehvac.com