

# PAC-SJ95MA-E/PAC-SJ96MA-E

## M-NET CONTROL ADAPTER FOR P-SERIES OUTDOOR UNITS



Job Name:

System Reference:

Date:

TABLE 1. LIST OF MODELS (PAC-SJ95MA-E)

Group A	Group B	Group C
PUY-A12,18NHA	PUZ/Y-A24,30,36,42NHA	PUZ/Y-A24,30NHA7(-BS)
PUY-A12,18NHA2	PUZ/Y-A24,30,36,42NHA2	PUZ/Y-A36,42NKA7(-BS)
PUY-A12,18NHA3	PUZ/Y-A24,30,36,42NHA3	
PUY-A12,18NHA4	PUZ/Y-A24,30,36,42NHA4	
PUY-A12,18NHA6(-BS)	PUZ/Y-A42NHA5	
PUZ-A18NHA	PUZ/Y-A24,30,36,42NHA6(-BS)	
PUZ-A18NHA2	PUZ/Y-A42NKA7(-BS)	
PUZ-A18NHA3	PUZ-HA24NHA	
PUZ-A18NHA4	PUZ-HA30/36NHA	
PUZ-A18NHA6(-BS)	PUZ-HA24NHA1	
	PUZ-HA30/36NHA2	
	PUZ-HA30/36NHA4	
	PUZ-HA30/36NHA5	
	PUZ-HA30/36NKA	
	PUZ-HA42NKA	
	PUZ-HA42NKA1	

TABLE 2. LIST OF MODELS (PAC-SJ96MA-E)

Group A
PUZ-A12,18NKA7(-BS)
PUY-A12,18NKA7(-BS)

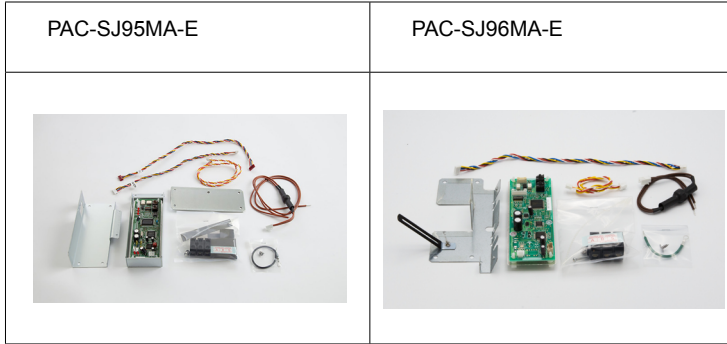

**FEATURES**

- Allows the P-Series outdoor units to communicate with the CITY MULTI® Controls Network
- Connects to outdoor unit
- Requires one converter per outdoor unit

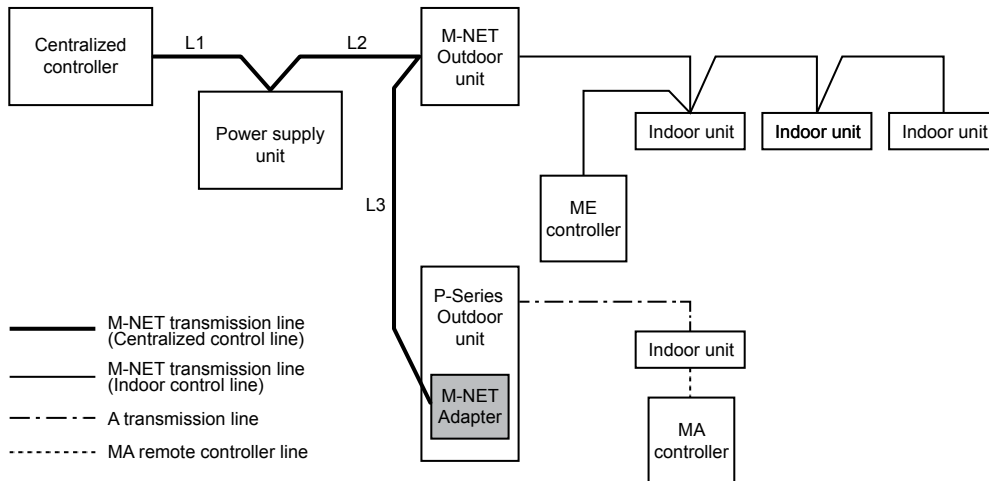

Maximum power feeding length for the centralized control line:  
 L1 ≤ 200 m (656 ft)  
 L2 + L3 ≤ 200 m (656 ft)

1340 Satellite Boulevard, Suwanee, GA 30024  
 Toll Free: 800-433-4822 www.mehvac.com