Outdoor Enclosure

Features

- Weatherproof Nema 4X / IP65, UV resistant, outdoor enclosures
- Ventilated, Gasket Sealed and Lockable Using Padlocks
- 1U 19" Rackmount Shelf
- Two Battery Shelves, Can Hold up to 400Ah of Battery
- Built in Mounting for DIN Rails on Inside Door and Back
- Built in DIN Rails on Inside Left and Right Sides
- Weatherproof Cable Feedthroughs
- Thermostatically Controlled Ventilation
- Wall and Pole Mountable (Includes Mounting Hardware)

Applications

- Wireless Base Stations and Clients
- Surveillance Cameras
- Wireless Bridge and Repeaters
- Remote Sensors
- Outdoor Utilities
- Solar and Wind Power

Description

The ENC-ST-24x24x16 outdoor enclosures are designed for applications that require a sturdy, weatherproof enclosure to house various electronics. They have gasket seals and are made from UV resistant materials for long service life. They can be wall or pole mounted with the included U-Bolts. The heavy duty pole mounting can accommodate up to a 4" diameter pole. For larger diameter poles, stainless steel straps are available commercially to accommodate almost any diameter pole.

The enclosure is designed to be passively ventilated and also includes a thermostatically controlled ventilation system that runs on 12VDC – 24VDC and turns on when interior temperature exceeds 45C.

Enclosure can be securely locked. Door closures are two stainless draw latches that can accommodate up to 9mm (0.35") diameter user supplied padlock.

Inside the enclosure are short DIN rails welded on the left and right walls. Din Rail mounting brackets are also available behind the middle shelf and on the door for mounting additional equipment. These DIN Rail mounting brackets can also be used for mounting a metal or wooden panel if desired. There is also a 1U 19" rackmount shelf (13.9" deep) towards the top of the enclosure. There are two battery shelves with integrated Velcro strap tie down features to hold up to 400Ah of seal lead acid batteries.

The enclosure comes with 3 RJ45 Feedthru cable glands for weatherproof cable entry/exit. The cable glands are mounted in the bottom of the enclosure on a removeable gasketed access plate.

The enclosure is corrosion resistant for long service life. Enclosure material is powder coated steel. All hardware is stainless steel.



ENC-ST-24x24x16
Steel Enclosure

Specifications

ENC-ST-24x24x16	
Enclosure Type	Powder Coated Steel
Weatherproofing	Nema 4X / IP65
Enclosure Mounting	Wall or pole mount with U Bolt or hose clamps
Interior Mounts	1U 19" Rackmount (13.9" depth), 4" Long Din Rails(4), Din Rail Mounts(4)
Enclosure External Size (LxWxD)	24.1 x 24.1 x 17.5" (612.5 x 612.5 x 445.6mm)
Enclosure Internal Size (LxWxD)	23.9 x 23.9 x 16.1" (608 x 608 x 409.5mm)
Weight	75lb (34kg)
Warranty	2 Years

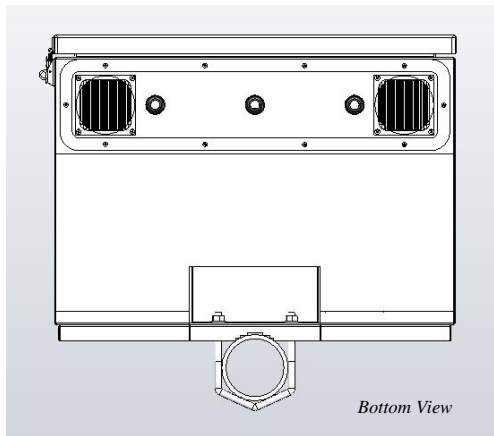
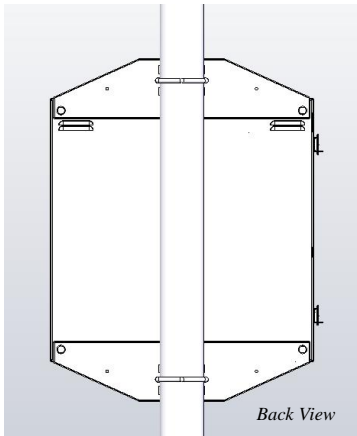
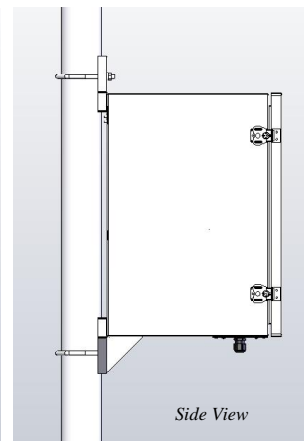
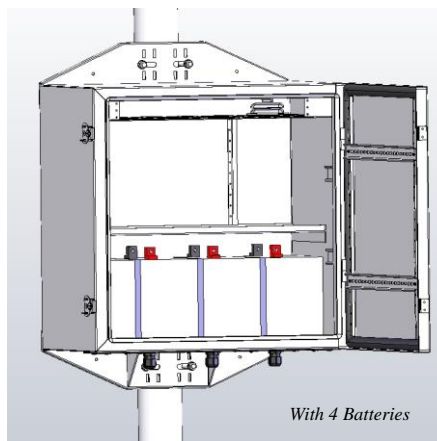
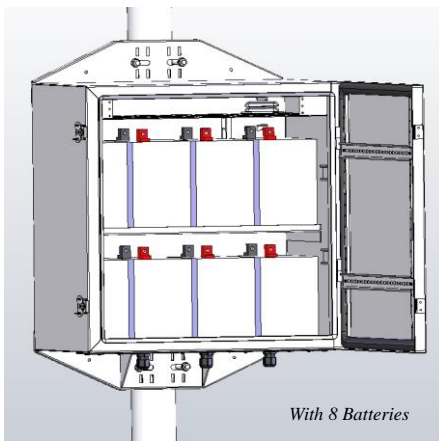

System Ordering:

ENC-ST-24x24x16 Outdoor Powder Coated Steel Enclosure 24x24x16"

For further information contact:

Tyconsystems.com



14641 S 800 W
Bluffdale, UT 84065
PH: 801-432-0003
FAX: 801-618-4220