

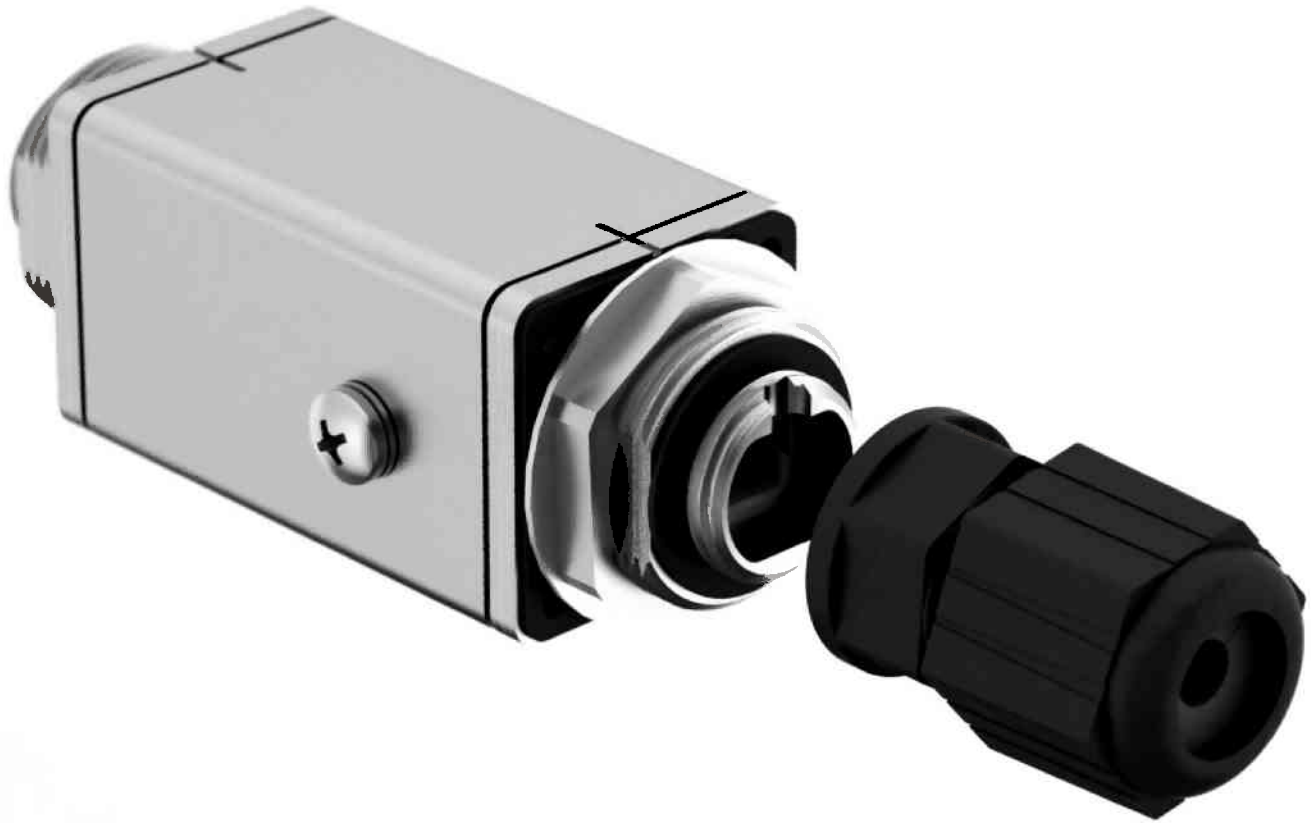

THIS DRAWING HAS BEEN GENERATED AND IS MAINTAINED BY A CAD SYSTEM. CHANGES SHALL ONLY BE INCORPORATED AS DIRECTED BY THE DESIGN ACTIVITY.

REVISIONS

LTR	DESCRIPTION	ECO NUM.	DATE	APPROVED
A	PRELIMINARY RELEASE	DD39910	2/25/10	DWR
B	UPDATE SPEC - SECTION 1	8773	4/7/10	DWR



MATERIAL:	DRAWN: MLH	DATE 2/12/10	 Transtector Systems, Inc. 10701 Airport Road, Hayden, ID 83835 800.882.9110 208.772.8515 www.transtector.com	
	CHECKED: DPM	2/25/10		
	ENGR. APPD: TOT	2/25/10		
	PROJ. APPD: DWR	2/25/10		
	APPROVED:			
TITLE: Product Specification Thunderbolt Weatherized Cat5e Protectors				
NOTICE: THE INFORMATION AND DESIGN CONTAINED HEREIN IS THE PROPERTY OF TRANSTECTOR SYSTEMS. WHO RESERVES ALL RIGHTS THERETO	SIZE A	CAGE 30992	DRAWING NUMBER 1400-771	REV B
	SCALE = N/A		PAGE 1 OF 4	

SURGE SUPPRESSOR MODELS: Thunderbolt Weatherized Cat5e Protectors

Part Description	Part Number
Thunderbolt 10/100BASE-T(X), 100BASE-T(X) PoE (TB 10/100/PoE)	1101-1028
Thunderbolt 1000BASE-T (TB GbE)	1101-1029
Thunderbolt 1000BASE-T PoE (TB GbE/PoE)	1101-1030

1. GENERAL DESCRIPTION: Transtector's Thunderbolt Series is engineered to protect all manner of outdoor Ethernet/Cat5e applications including 10/100/1000Base-T(X) (including PoE) by mitigating the effects of common induced lightning transients. The aluminum housing offers weather-tight mechanical mounting through bulk head apertures. This device incorporates the advantage of coordinated high-power gas discharge tube (GDT) and low capacitance transient blocking technology in a single package.

Each protection module type is clearly marked on the face adjacent to the ground screw to show the correct orientation of the connectors to the "unprotected" outside world and "protected" equipment as well as indicate the compatible Ethernet protocols for the module. Because many POE and GigE protocols use the same cat5e cable and connectors, care must be taken by the installer and operator to be sure the cable installation and operating conditions are supported by the Thunderbolt protector. Call Transtector Systems Applications Engineering for assistance at 800-882-9110 (outside of USA, 208-772-8515)

The Thunderbolt series provides a #10 ground screw as well as a molded RJ-45 connector shroud with cable gland and mounting hardware as depicted in Figure 1. The RJ45 shroud is compatible with EuroComp, Inc, IP67 rated strain relief model LTWRJS-00BFFA-SL7001.

All protection configurations offer straight through pin-outs from the input to output connectors. In the unlikely event of surge protection self sacrifice, the individual protection modules will reliably fail short to disrupt communication.

2. ELECTRICAL:

2.1 TB 10/100/PoE PROTECTION MODULE:

2.1.1	Compatible Applications	10/100Base-T(X); 100Base-T(X) PoE Mode B
2.1.2	Data Rate	100Mb/s
2.1.3	Nominal Operating Voltage	48Vdc
2.1.4	Maximum Continuous Operating Voltage	60Vdc
2.1.5	Connector Style	RJ45 Cat5e UTP
2.1.6	Maximum Capacitance per Pin	3pF
2.1.7	Protected Signal Pins (GDT + TBU)	(1,2) & (3,6)
2.1.8	Protected PoE Pins (GDT Only)	(4,5) & (7,8)
2.1.9	Nominal GDT Spark Over Voltage	150V ± 20%
2.1.10	Peak Surge Suppression Level per Pin	5,000A 8/20µs (10 Operations)

2.2 TB GbE PROTECTION MODULE:

2.2.1	Compatible Applications	1000Base-T
2.2.2	Data Rate	1000Mb/s
2.2.3	Nominal Operating Voltage	3.3Vdc
2.2.4	Maximum Continuous Operating Voltage	11Vdc
2.2.5	Connector Style	RJ45 Cat5e UTP
2.2.6	Maximum Capacitance per Pin	3pF
2.2.7	Protected Signal Pins (GDT + TBU)	(1,2), (3,6), (4,5), & (7,8)
2.2.8	Nominal GDT Spark Over Voltage	150V ± 20%
2.2.9	Peak Surge Suppression Level per Pin	5,000A 8/20µs (10 Operations)



NOTICE: THE INFORMATION AND DESIGN CONTAINED HEREIN IS THE PROPERTY OF TRANSTECTOR SYSTEMS. WHO RESERVES ALL RIGHTS THERE TO.

SIZE	CAGE		
A	30992	1400-771	B
SCALE = N/A		Page 2 of 4	

2.3 TB GbE/PoE PROTECTION MODULE:

2.3.1	Compatible Applications	1000Base-T(X) PoE
2.3.2	Data Rate	1000Mb/s
2.3.3	Nominal Operating Voltage	48Vdc
2.3.4	Maximum Continuous Operating Voltage	60Vdc
2.3.5	Connector Style	RJ45 Cat5e UTP
2.3.6	Maximum Capacitance per Pin	3pF
2.3.7	Protected Signal/PoE Pins (GDT Only)	(1,2), (3,6), (4,5) & (7,8)
2.3.8	Nominal GDT Spark Over Voltage	150V ± 20%
2.3.9	Peak Surge Suppression Level per Pin	5,000A 8/20µs (10 Operations)

3. ENVIRONMENTAL:

3.1.	Operating/Storage Temperature:	-40°C to +75°C
3.2.	Relative Humidity:	99% (non-condensing)

4. MECHANICAL:

4.1.	Size, suppressor with no shrouds:	3.6cm x 3.6cm x 10.cm long.
4.2.	Weight, Individual Module	.15lbs

5. INSTALLATION: The Thunderbolt is intended to be installed onto any grounded metal frame bulk head or bracket. The unit can be used with the thunder kit weather gasket or EMI gasket to achieve up to 60 dB isolation. Refer to figure 1 for mechanical dimensions and figure 2 for hardware accessories.

Bulkhead Installation Procedure

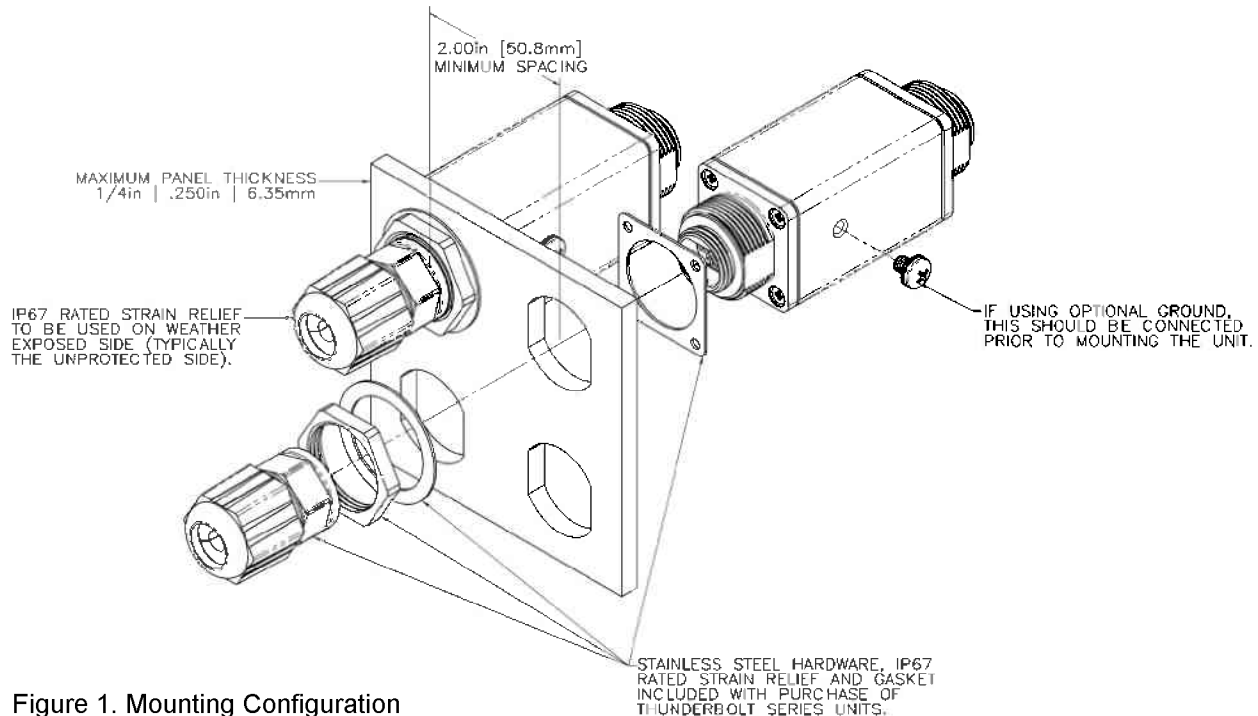

Figure 1. Mounting Configuration

- 5.1. Install the Thunderbolt protector into the prescribed area. The Thunderbolt mounts through a 29mm hole in the bulkhead or enclosure. Be sure to orient the device with the “unprotected” side oriented out to the exposed wire direction (see Figure 1).
- 5.2. Attach an optional grounding conductor, 10awg minimum (not provided) between the ground lug on the Thunderbolt and the nearest Master Ground Bar connection. The grounding wires should be as short as possible (see Figure 2).
- 5.3. Slide the Cat5e cable through the strain relief cap first. Then slide through the connector shroud. Install the IP67 rated strain relief over the cable between the cap and connector shroud. Place the shroud gasket on the unit over the M20 x 1.5 threaded portion. Plug the connector into the unit and torque the connector shroud down with 5 to 7 in-lbf to compress the gasket (do not over-tighten the connector shroud on the gasket). Slide the IP67 rated strain relief into the connector shroud (leaving approximately 1mm of the strain relief exposed). Torque the strain relief cap onto the connector shroud with 3 to 5 in-lbf. (see Figure 3).
- 5.4. Install the Cat5e suitable cable to the “protected” side of the Thunderbolt to the sensitive equipment on the “indoor” side. If it is desired to achieve IP67 protection on the “protected” side, an additional molded RJ-45 connector shroud with cable gland can be acquired from EuroComp, Inc, IP67 rated strain relief model LTRWJS-00BFFA-SL7001.
- 5.5. If shielded Cat5e cable is being used, then one end of the shield should be grounded to a solid Earth Ground, preferably to a master ground bar.

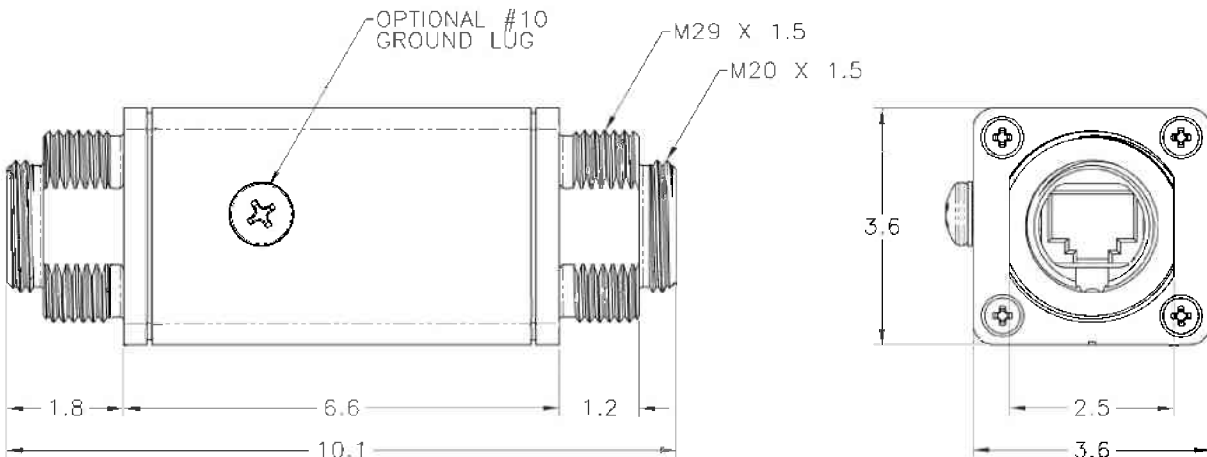

Figure 2. Mechanical outline (cm)

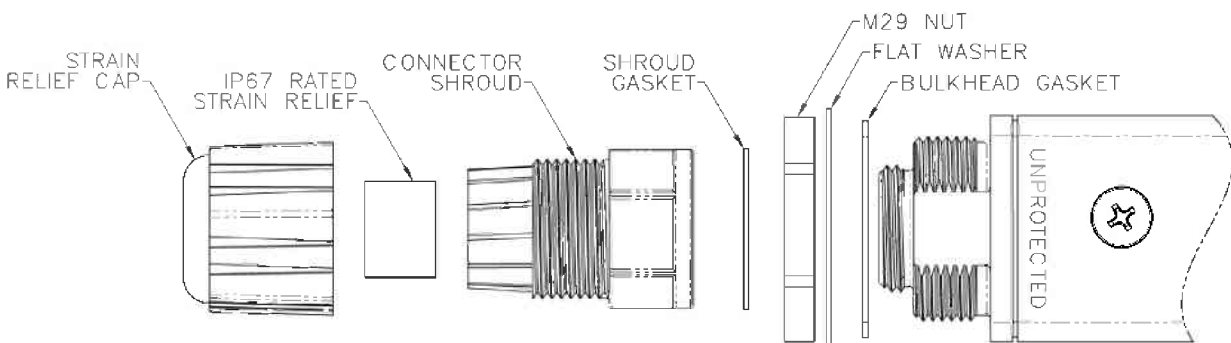

Figure 3. Installation Hardware Accessories (provided with unit)