

THIS DRAWING HAS BEEN GENERATED AND IS MAINTAINED BY A CAD SYSTEM. CHANGES SHALL ONLY BE INCORPORATED AS DIRECTED BY THE DESIGN ACTIVITY.

REVISIONS				
LTR	DESCRIPTION	ECO NUM.	DATE	APPROVED
O	PRODUCTION RELEASE		7/31/02	CDD
A	REMOVE DIN CONNECTORS	4812	3/18/03	MLH
B	ADD COMMON MODE	4839	4/15/03	JDW



UNLESS OTHERWISE SPECIFIED DIM. IN INCHES BEFORE PLATING	DRAWN:	DATE
	JDW	7/31/02
	CHECKED:	
	JEB	8/5/02
MATERIAL:	ENGR. APPD:	
	DWR	8/5/02
NOTED	PROJ. APPD:	
	CDD	8/6/02
	APPROVED:	



TITLE:	SPECIFICATION ALPU-TSU		
--------	---------------------------	--	--

SIZE	CAGE	DRAWING NUMBER	REV
A	30992	1400-458	B
SCALE = N/A		PAGE 1 OF 3	

NOTICE: THE INFORMATION AND DESIGN CONTAINED HEREIN IS THE PROPERTY OF TRANSTECTOR SYSTEMS, WHO RESERVES ALL RIGHTS THERETO

SURGE SUPPRESSOR: ALPU-TSU

1. **GENERAL DESCRIPTION:** The ALPU-TSU surge suppressor is a high-speed, high-current solid state device designed to protect (1) Ethernet CAT-5 line and (1) 48 VDC lines. **The ALPU-TSU uses only silicon avalanche suppression diodes (SASD).** It connects to the service in a pass through configuration. The input and output connections are made at two "screw type" terminal blocks. Both the input and output harnesses pass into the suppressor housing via waterproof strain reliefs. The molded plastic enclosure is also waterproof, and features integrated mounting holes that are concealed by the cover and integrated gasket.

2. PERFORMANCE REQUIREMENTS:

2.1. Electrical Service:

2.1.1. Ethernet

2.1.1.1. **Transfer rate**.....CAT-5 10/100Mb/s
 2.1.1.2. **Configuration** 2 pair
 2.1.1.3. **Input Connection** Screw-Term Block (22-16 AWG)
 2.1.1.4. **Protection Modes** Line to Line, Line to Ground
 2.1.1.5. **Maximum Continuous Operating Voltage**..... 13 VDC

2.1.2. 48 VDC

2.1.2.1. **Service Voltage**..... 48 VDC
 2.1.2.2. **Configuration**4 wire
 2.1.2.3. **Input Connection** Screw-Term. Block (22-16 AWG)
 2.1.2.4. **Protection Modes** Line to Line, Line to Ground
 2.1.2.5. **Maximum Continuous Operating Voltage**..... 60 VDC

2.2. Electrical Performance:

2.2.1. Ethernet

2.2.1.1. Testing

2.2.1.1.1. **I_{pk}**(Tested to IEEE 10/1000us Long Wave)200A peak
 2.2.1.1.2. **I_{pk}**(Tested to IEEE 8/20us Combination Wave)2500A peak

2.2.1.2. **Response Time (Max)**.....5 nanoseconds

2.2.1.3. **Standby Power (Max)** < 0.5 Watt

2.2.1.4. **Peak Power**.....5000 Watts

2.2.2. 48 VDC

2.2.2.1. Testing

2.2.2.1.1. **I_{pk}**(Tested to IEEE 10/1000us Long Wave)200A peak

2.2.2.1.2. **I_{pk}**(Tested to IEEE 8/20us Combination Wave)2500A peak

2.2.2.2. **Response Time (Max)**.....5 nanoseconds

2.2.2.3. **Standby Power (Max)** < 0.5 Watt

2.2.2.4. **Peak Power**.....20,000 Watts

3. ENVIRONMENTAL:

3.1. **Operating Temperature:**.....-40°C to +80°C

3.2. **Storage Temperature:**-40°C to +80°C

3.3. **Relative Humidity:**.....99% (non-condensing)



NOTICE: THE INFORMATION AND DESIGN CONTAINED HEREIN IS THE PROPERTY OF TRANSTECTOR SYSTEMS. WHO RESERVES ALL RIGHTS THERETO.

SIZE
A

CAGE
30992

1400-458

B

SCALE =

4. MECHANICAL/INSTALLATION

4.1. Enclosure dimensions: The suppressor is housed in a molded plastic enclosure that is 6.13 in long, 4.5 in wide and 2.5 in tall. The enclosure mounts with #6 hardware.

4.2. Mounting data: See diagram below.

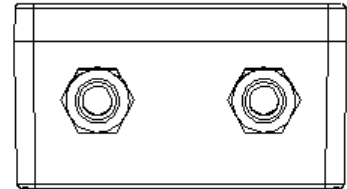
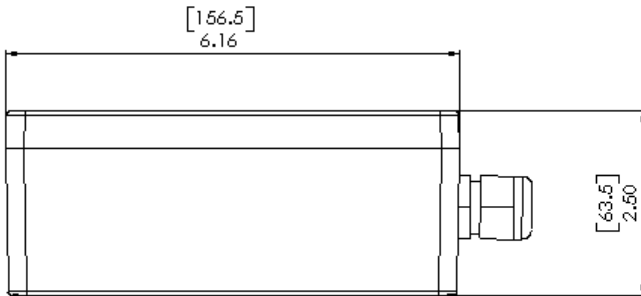
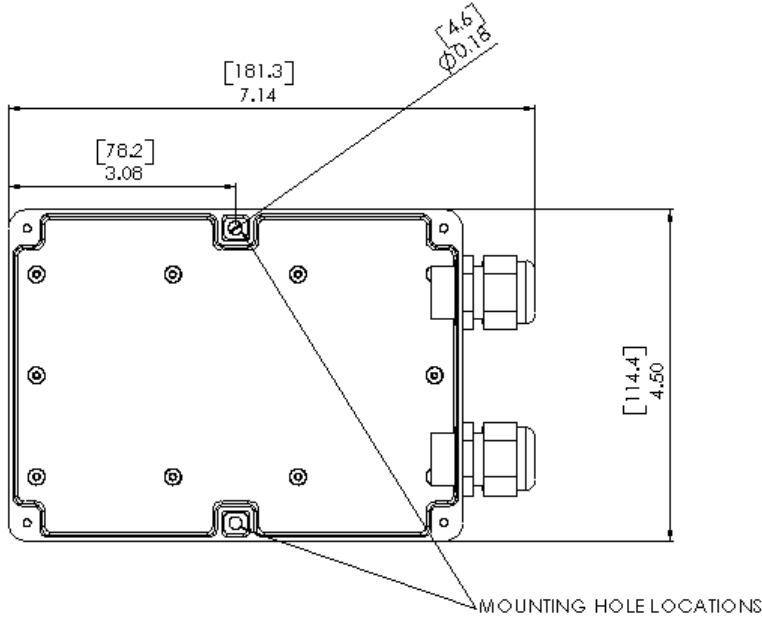

[X.XXX = mm] X.XX = inches

4.3. Wiring data

4.3.1. The ALPU-TSU is designed to accept (2) multi-conductor cables with outside diameter ranging from 1/4" to 3/8".